

BINKS TROPHY AA 4400 HVLP OR LVMP AIR-ASSIST AIRLESS SPRAY GUNS



Flat tip versions

- 4400-HF0000 HVLP AA10 AIR CAP
- 4400-H10000 HVLP AA10+ AIR CAP
- 4400-H20000 HVLP 9X-H+ AIR CAP
- 4400-LF0000 LVMP 9X-L AIR CAP



Twist tip versions

- 4400-HT0000 HVLP
- 4400-LT0000 LVMP

The following instructions provide the necessary information for the proper operation and preventive maintenance of your new TROPHY AA Air-Assist Airless Spray Gun.

Please read and understand all information in this document in order to get the maximum performance from your new TROPHY AA spray gun.

With your new TROPHY AA spray gun, the paint or other material to be sprayed is primarily atomized as it passes through the carbide tip. The air cap will also add a secondary atomization, based on its configuration. This is done by utilizing a separate air supply, to the gun.

You may also control the pattern size using the spreader valve. This dual atomization and shaping produces an exceptionally fine and even spray pattern. The result of this spray pattern is an even finish that lends itself to products that need an exceptionally fine finish with reduced overspray and VOC emissions.

SPECIFICATIONS	
Maximum fluid pressure:	303 bar [4,400 psi]
Maximum air inlet pressure:	7 bar [105 psi]
Gun Body material:	Forged Aluminum
Fluid Path material:	Stainless Steel
Fluid Seat Material:	Tungsten Carbide
Fluid inlet connection:	1/4" NPS (m)
Air inlet connection:	1/4" BSP / NPS (m)

Product Description/Object of Declaration: AIR-ASSIST
AIRLESS SPRAY GUN

This Product is designed for use with: Solvent and Water based Materials

Suitable for use in hazardous area: Zone 1

Protection Level: II 2 G X

Notified body details and role: Element Materials Technology. WN8 9PN UK
Lodging of Technical file

This Declaration of Conformity /incorporation is issued under the sole responsibility of the manufacturer: Carlisle Fluid Technologies Inc.,
320 Phillips Ave.,
Toledo, OH 43612

EU Declaration of Conformity



The object of the declaration described above is in conformity with the relevant Union harmonisation legislation:

Machinery Directive 2006/42/EC
ATEX Directive 2014/34/EU
by complying with the following statutory documents and harmonized standards:
EN ISO 12100:2010 Safety of Machinery - General Principles for Design
BS EN 1953:2013 Atomising and spraying equipment for coating materials - Safety requirements
EN 13463-1:2009 Non electrical equipment for use in potentially explosive atmospheres - Basic methods and requirements

Providing all conditions of safe use / installation stated within the product manuals have been complied with and also installed in accordance with any applicable local codes of practice.

Signed for and on behalf of
Carlisle Fluid Technologies:

DJ Hasselschwert
11-Jul-17

(Vice President: Global
Product Development)
Toledo, OH 43612

4-3193R-1

In this part sheet, the words **WARNING**, **CAUTION** and **NOTE** are used to emphasize important safety information as follows:

WARNING

Hazards or unsafe practices which could result in severe personal injury, death or substantial property damage.

CAUTION

Hazards or unsafe practices which could result in minor personal injury, product or property damage.

NOTE

Important installation, operation or maintenance information.

WARNING

Read the following warnings before using this equipment.



READ THE MANUAL

Before operating finishing equipment, read and understand all safety, operation and maintenance information provided in the operation manual.



OPERATOR TRAINING

All personnel must be trained before operating finishing equipment.



EQUIPMENT MISUSE HAZARD

Equipment misuse can cause the equipment to rupture, malfunction, or start unexpectedly and result in serious injury.



LOCK OUT / TAG-OUT

Failure to de-energize, disconnect, lock out and tag-out all power sources before performing equipment maintenance could cause serious injury or death.



AUTOMATIC EQUIPMENT

Automatic equipment may start suddenly without warning.



PRESSURE RELIEF PROCEDURE

Always follow the pressure relief procedure in the equipment instruction manual.



KEEP EQUIPMENT GUARDS IN PLACE

Do not operate the equipment if the safety devices have been removed.



KNOW WHERE AND HOW TO SHUT OFF THE EQUIPMENT IN CASE OF AN EMERGENCY



WEAR SAFETY GLASSES

Failure to wear safety glasses with side shields could result in serious eye injury or blindness.



INSPECT THE EQUIPMENT DAILY

Inspect the equipment for worn or broken parts on a daily basis. Do not operate the equipment if you are uncertain about its condition.



NEVER MODIFY THE EQUIPMENT

Do not modify the equipment unless the manufacturer provides written approval.



NOISE HAZARD

You may be injured by loud noise. Hearing protection may be required when using this equipment.

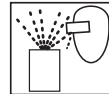

PROJECTILE HAZARD

You may be injured by venting liquids or gases that are released under pressure, or flying debris.



PINCH POINT HAZARD

Moving parts can crush and cut. Pinch points are basically any areas where there are moving parts.



STATIC CHARGE

Fluid may develop a static charge that must be dissipated through proper grounding of the equipment, objects to be sprayed and all other electrically conductive objects in the dispensing area. Improper grounding or sparks can cause a hazardous condition and result in fire, explosion or electric shock and other serious injury.



WEAR RESPIRATOR

Toxic fumes can cause serious injury or death if inhaled. Wear a respirator as recommended by the fluid and solvent manufacturer's Safety Data Sheet.



TOXIC FLUID & FUMES

Hazardous fluid or toxic fumes can cause serious injury or death if splashed in the eyes or on the skin, inhaled, injected or swallowed. LEARN and KNOW the specific hazards of the fluids you are using.



FIRE AND EXPLOSION HAZARD

Improper equipment grounding, poor ventilation, open flame or sparks can cause a hazardous condition and result in fire or explosion and serious injury.



MEDICAL ALERT

Any injury caused by high pressure liquid can be serious. If you are injured or even suspect an injury:

- Go to an emergency room immediately.
- Tell the doctor you suspect an injection injury.
- Show the doctor this medical information or the medical alert card provided with your airless spray equipment.
- Tell the doctor what kind of fluid you were spraying or dispensing.



GET IMMEDIATE MEDICAL ATTENTION

To prevent contact with the fluid, please note the following:

- Never point the gun/valve at anyone or any part of the body.
- Never put hand or fingers over the spray tip.
- Never attempt to stop or deflect fluid leaks with your hand, body, glove or rag.
- Always have the tip guard on the spray gun before spraying.
- Always ensure that the gun trigger safety operates before spraying.



PROP 65 WARNING

WARNING: This product contains chemicals known to the State of California to cause cancer and birth defects or other reproductive harm.

IT IS THE RESPONSIBILITY OF THE EMPLOYER TO PROVIDE THIS INFORMATION TO THE OPERATOR OF THE EQUIPMENT. FOR FURTHER SAFETY INFORMATION REGARDING THIS EQUIPMENT, SEE THE GENERAL EQUIPMENT SAFETY BOOKLET (77-5300).

Binks reserves the right to modify equipment specification without prior notice.

INSTALLATION

NOTE

Before proceeding, make sure trigger lock is engaged.

1. Connect your high-pressure fluid hose to the gun fluid inlet and tighten securely.
2. Connect your air hose to the gun air connection and tighten securely.
3. Slowly increase air to the pump to obtain a fluid pressure at the gun's lower end of the pressure range. A typical starting fluid pressure is 70 bar [1000 psi]. Actual starting pressure points may be higher or lower and be dependent on the type of pump used, the type of material sprayed, and the spray gun itself.
4. Using the control knob of the gun air regulator at the air control, set the gun shaping air pressure at 0 bar [0 psi].
5. To test the spraying pattern, spray a sample piece of wood or cardboard with a fast pass about 30cm [1 ft] away from the surface. The results of the test will allow you to determine the uniformity of the particle size and spraying pattern.
6. If the spraying pattern develops tails or is not uniform, gradually increase the air pressure as necessary to develop a uniform spraying pattern. 1 bar [14 psi] is the maximum inlet air pressure for HVLP air caps, or use 1.4-2.8 bar [20-40 psi] inlet air pressure for LVMP air caps.
7. If the pattern is still unacceptable, you may gradually increase the fluid pump air pressure in 0.7 bar [10 psi] increments using the fluid pump air regulator control knob. Repeat step 6, as needed.
8. Once the quality of spray is acceptable, begin spraying. If the spraying rate is too slow to keep up with the production line speed, or if the quantity of material sprayed is inadequate for acceptable coverage, repeat step 7, until desired pattern and material quantity is achieved. If the maximum fluid pressure is reached before the required material coverage and spraying speed are achieved, you may need to switch to a different fluid tip.

FLUID TIP SELECTION

Factors to consider in selecting a fluid tip for an air-assist airless spray gun include:

- The size of the parts being sprayed.
- The production line speed
- The material flow rate and film thickness.
- The viscosity of the material applied
- The type of material applied.
- The quality of atomization of the coating required.

The selection of a fluid tip necessary to perform a specific spraying job is best determined through a combination of experimentation and expert advice from your material and equipment suppliers.

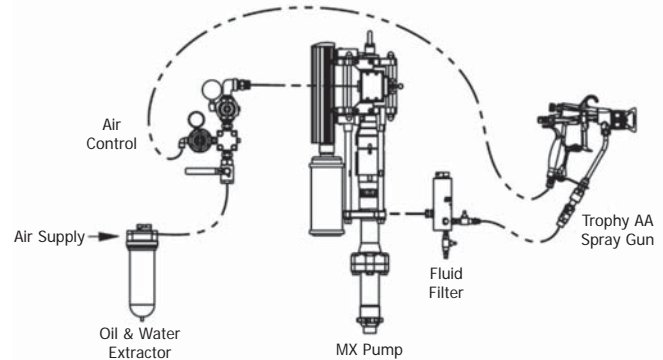

SPRAY PATTERN ADJUSTMENT

- Turn the spreader valve knob indicated below counterclockwise to decrease the pattern size; clockwise to increase pattern size.

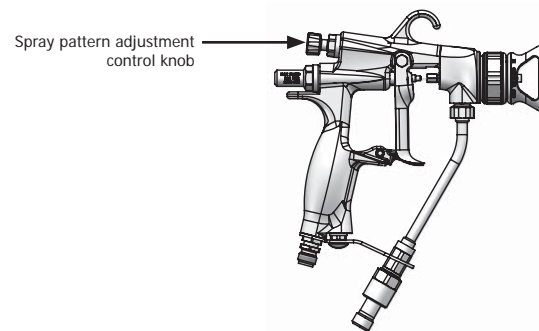

NOTE

For HVLP spray, spray pattern adjustment feature requires 1 bar [14 psi] maximum of air inlet pressure.

For LVMP spray, spray pattern adjustment requires approximately 1.4-2.8 bar [20-40 psi] of air inlet pressure. Higher fluid pressures will require a higher air inlet pressure to accommodate pattern adjustment.

FLUID HOSES

Air-assist airless spray guns operate at fluid pressures higher than operating pressures of air spray guns. As a result, when operating an air-assist airless spray gun, it is critical to select the appropriate fluid hose that is rated for the pressure range at which the airless gun is operated.

⚠ WARNING

The spray gun must be earthed to dissipate any electrostatic charges which may be created by fluid or air flows. This can be achieved through the spray gun mounting, or conductive air/fluid hoses. Electrical bond from the spray gun to earth should be checked and a resistance of less than 10⁶ Ohms is required.

GENERAL TROUBLESHOOTING

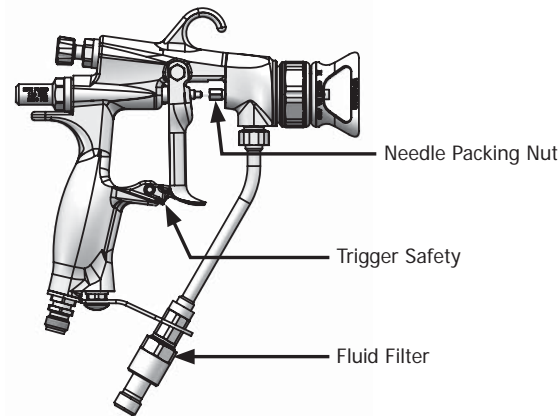

PROBLEM	CAUSE	REMEDY
Fluid leaking from needle packing	Worn needle packing or needle shaft	Replace air valve & fluid needle assembly, item 5.
	Loose needle packing	Tighten packing nut gradually until leak stops.
Fluid leaking from the front of the gun	Worn or damaged needle ball	Replace air valve & fluid needle assembly, item 5.
	Worn seat assembly	Replace fluid nozzle, item 9.
Fluid in air passages	Spray tip seal leaking	Tighten air cap & nozzle guard assembly, item 11 or 13. Replace carbide tip seal. RS-5000-K5 or RS-5000-K10
	Leaking around fluid seat	Tighten or replace fluid nozzle, item 9.
Fluid slow to shut off	Fluid buildup on needle assembly	Clean or replace air valve & fluid needle assembly, item 5.
No fluid output when gun is triggered	Tip orifice is plugged	Flat tips - Turn off fluid supply. Relieve pressure into a closed earth-grounded container. Engage trigger safety. Remove air cap/nozzle guard assembly and spray tip. Clean or replace the spray tip, item 12. Twist tips – Rotate twist tip 180° within the air cap, then spray into a closed earth-grounded container to try to clear tip of any debris. If that fails, turn off fluid supply. Engage trigger safety. Remove air cap/nozzle guard assembly and spray tip. Clean or replace the twist tip, item 10.
	Needle is damaged or broken	Turn off fluid supply. Relieve pressure into a closed earth-grounded container. Engage trigger safety. Replace air valve & fluid needle assembly, item 5.
	Fluid filter is plugged	Turn off fluid supply. Relieve pressure into a closed-grounded container. Engage trigger safety. Turn off air supply to pump and relieve fluid pressure from pump using bypass valve on pump. Very slowly loosen the fluid hose connection at the gun to relieve any pressure in the hose. Remove the fluid hose. Using two wrenches, one to hold the fluid tube in place, and the other to remove the nut. Open the fluid filter, and clean or replace the filter element, item 17e.
	Fluid hose is plugged	Turn off fluid supply. Relieve pressure into a closed-grounded container. Engage trigger safety. Turn off air supply to pump and relieve fluid pressure from pump using bypass valve on pump. Very slowly loosen the fluid hose connection at the gun to relieve any pressure in the hose. Remove the hose and clear obstruction, or replace hose.

TROUBLESHOOTING SPRAY PERFORMANCE

 **CAUTION**

Always engage trigger lock and relieve fluid pressure.

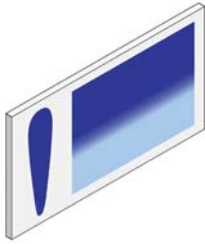
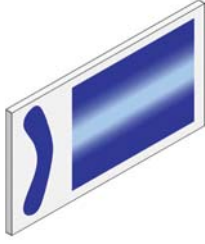
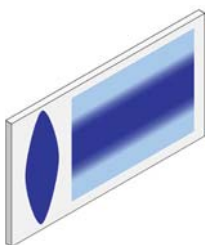
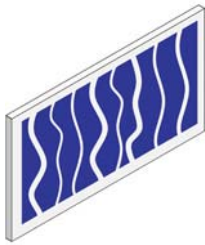
PROBLEM	CAUSE	CORRECTION
Heavy top or bottom pattern. 	Material build-up on air cap, plugged horn holes, center holes or jets.	Soak cap or tip in suitable solvent and thoroughly clean.
	Material build-up on fluid tip exterior or partially plugged fluid tip.	Replace fluid tip or air cap if necessary.
	Fluid tip or cap dirty or damaged.	Replace fluid tip or air cap if necessary.
Heavy right or left side pattern. 	Left or right side horn holes plugged.	Soak cap or tip in suitable solvent and thoroughly clean.
	Dirt or damage on left or right side of fluid tip exterior.	Replace fluid tip or air cap if necessary.
Remedies for the top-heavy, bottom-heavy, right-heavy and left-heavy patterns.		
Determine if the obstruction is on the air cap or the fluid tip. Do this by making a test spray pattern. Then, rotate the air cap and tip one-half turn and spray another pattern. If the defect is inverted, obstruction is on the air cap. Clean the air cap as previously instructed. Also check for dried paint just inside the cap center hole opening, remove by washing with solvent.		
If the defect is not inverted, it is on the fluid tip. Clean tip. If problem persists, renew tip.		
Heavy center pattern. 	Pattern adjustment valve set too low.	Turn out counter clockwise to achieve correct pattern.
	Too much material.	Reduce fluid pressure.
	Material too thick.	Thin to correct consistency.
	Atomizing air pressure too low.	Increase air pressure.
Intermittent or 'fluttering' spray fan. 	Fluid tip not seated correctly in gun head.	Remove fluid tip, clean components, check cone seating on tip and gun for damage or contamination.
	Partially obstructed fluid passage or hose.	Clean or replace.

TROUBLESHOOTING SPRAY PERFORMANCE

 **CAUTION**

Always engage trigger lock and relieve fluid pressure.

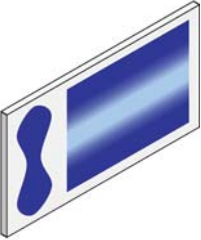
PROBLEM	CAUSE	CORRECTION
Split spray pattern. 	Not enough material flow.	Increase fluid flow by changing fluid tip size, or increase fluid pressure.
Excessive bounce-back.	Too much atomization air pressure.	Reduce air pressure.
	Gun too far from surface.	Check distance.
Runs and sags.	Too much fluid flow.	Adjust gun or reduce fluid pressure.
	Material too thin.	Mix properly or apply light coats/reduce fluid flow.
	Gun tilted at an angle.	Mount gun at right angle to work.
Thin, sandy coarse finish drying before it flows out.	Gun too far from surface.	Check distance.
	Too much air pressure.	Reduce air pressure and check spray pattern.
	Fluid flow too low.	Increase fluid flow by changing fluid tip size, supply pressure.

TROPHY AA 4400 SPRAY GUN ASSEMBLIES

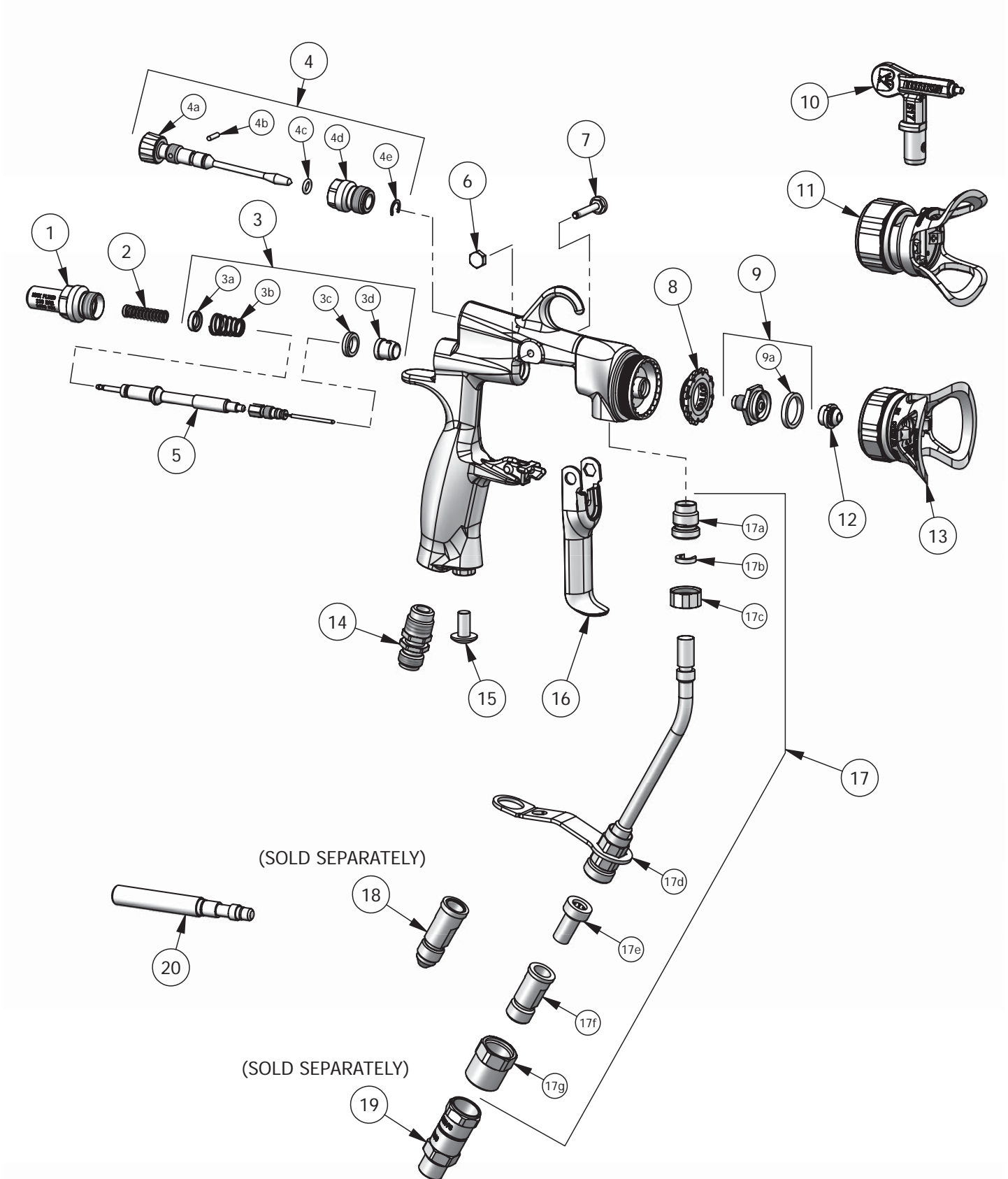

PARTS LIST

ITEM NO.	PART NO.	DESCRIPTION	4400-HF0000 FLAT TIP QTY.	4400-H10000 FLAT TIP QTY.	4400-H20000 FLAT TIP QTY.	4400-LF0000 FLAT TIP QTY.	4400-HT0000 TWIST TIP QTY.	4400-LT0000 TWIST TIP QTY.
1	54-6008	AIR VALVE HOUSING	1	1	1	1	1	1
2	54-5935-K5	NEEDLE RETURN SPRING KIT (MULTI-PACK)	1	1	1	1	1	1
3	54-6131-K	SPINDLE SEAL & SPRING KIT	1	1	1	1	1	1
3a		REAR SEAL	1	1	1	1	1	1
3b		AIR VALVE SPRING	1	1	1	1	1	1
3c		VALVE SEAL	1	1	1	1	1	1
3d		FRONT SEAL	1	1	1	1	1	1
4	54-5815	SPREADER VALVE ASSEMBLY	1	1	1	1	1	1
4a		VALVE STEM	1	1	1	1	1	1
4d		VALVE BODY	1	1	1	1	1	1
4c	SN-71X-K2	● O-RING (MULTI-PACK)	1	1	1	1	1	1
4b		● PIN	1	1	1	1	1	1
4e		● SNAP RING	1	1	1	1	1	1
5	54-5937	AIR VALVE & FLUID NEEDLE ASSEMBLY	1	1	1	1	1	1
6	54-6114	TRIGGER NUT	1	1	1	1	1	1
7	54-6115	TRIGGER SCREW	1	1	1	1	1	1
8	SPA-71-K5 SPA-71-K10	BAFFLE PLATE (MULTI-PACK)	1	1	1	1	1	1
9	54-5799-K	FLUID NOZZLE & GASKET (FLAT TIP)	1	1	1	1	-	-
	54-5832-K	FLUID NOZZLE & GASKET (TWIST TIP)	-	-	-	-	1	1
9a	SPA-98-K5	GASKET (MULTI-PACK)	-	-	-	-	-	-
	SPA-98-K10	GASKET (MULTI-PACK)	-	-	-	-	-	-
10	SEE PAGE 10	REVERSABILE TWIST TIP	-	-	-	-	-	-
11	54-5924-K	HVLP TWIST TIP AIR CAP ASSEMBLY	-	-	-	-	1	-
	54-5925-K	LVMP TWIST TIP AIR CAP ASSEMBLY	-	-	-	-	-	1
12	SEE PAGE 10	FLAT TIP ASSEMBLY	-	-	-	-	-	-
	SEE PAGE 10	FINE FINISH FLAT TIP ASSEMBLY	-	-	-	-	-	-
13	54-5878-K	9X-H+ AIR CAP ASSEMBLY (4400-HF0000)	1	-	-	-	-	-
	54-5890-K	AA10 AIR CAP ASSEMBLY (4400-H10000)	-	1	-	-	-	-
	54-6030-K	AA10+ AIR CAP ASSEMBLY (4400-H20000)	-	-	1	-	-	-
	54-5797-K	9X-L AIR CAP ASSEMBLY (4400-LF0000)	-	-	-	1	-	-
14	SN-9-K3	AIR INLET (MULTI-PACK)	1	1	1	1	1	1
15		SLOTTED ROUND HEAD SCREW, 1/4" - 20 x 1/2", S.S.	1	1	1	1	1	1
16	54-6019	■ TRIGGER	1	1	1	1	1	1
17	54-6015	FLUID TUBE ASSEMBLY	1	1	1	1	1	1
17a		FLUID TUBE ADAPTER	1	1	1	1	1	1
17b	54-5896-K5	FLUID TUBE RETAINER (MULTI-PACK)	1	1	1	1	1	1
17c	54-5899	FERRULE NUT	1	1	1	1	1	1
17d	54-6017	FILTER BRACKET	1	1	1	1	1	1
17e	54-1835	□ FLUID FILTER, 100 MESH	1	1	1	1	1	1
17f	54-4726-K	DISC FILTER BODY, 1/4" NPS (M)	1	1	1	1	1	1
17g	54-4726-K	DISC FILTER RETAINER	1	1	1	1	1	1
18	54-5897	JIC #5 FLUID INLET FITTING (SOLD SEPARATELY)	-	-	-	-	-	-
19	72-2360	SWIVEL ADAPTER, 1/4" NPS M X F (SOLD SEPARATELY)	-	-	-	-	-	-
20	SPN-7	TOOL	1	1	1	1	1	1

Parts are included within the following packing kits:

- Parts are included in kit: GTI-428-K5

ALTERNATE ITEMS (SOLD SEPARATELY):

- 54-1836 FLUID FILTER, 60 MESH
- 54-6018 TRIGGER, SHORT PULL

TROPHY AA 4400 AIR CAP ASSEMBLIES

FLAT TIP AIRCAPS

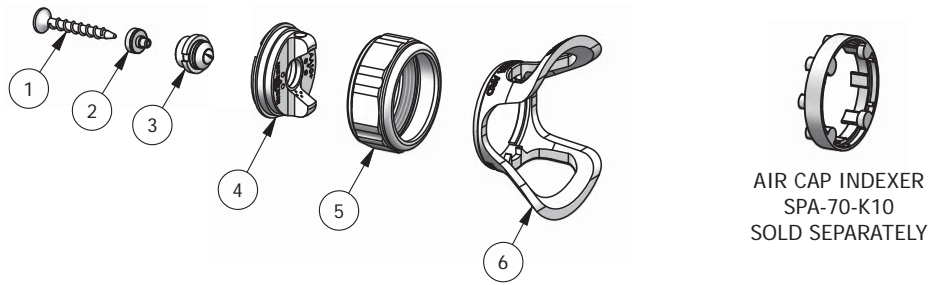

AIR CAP INDEXER
SPA-70-K10
SOLD SEPARATELY

ITEM NO.	PART NO.	DESCRIPTION	HVLP				LVMP
			54-6030-K	54-5890-K	54-5878-K	54-5795-K	54-5797-K
			AA10+	AA10	9X-H+	9X-H	9X-L
1		SEAL REMOVAL TOOL	—	—	—	—	—
2	see pages 14-15	REPLACABLE TIP SEAL	—	—	—	—	—
3	see pages 14-15	RS SPRAY TIP	—	—	—	—	—
4		AIR CAP COLOR	BLUE	BROWN	BLACK	SILVER	SILVER
5		RETAINING RING	1	1	1	1	1
6	54-5794	FLAT TIP GUARD	1	1	1	1	1

TEST AIR CAP KITS: 54-6036 54-5836-K

REVERSIBLE TWIST TIP AIRCAPS

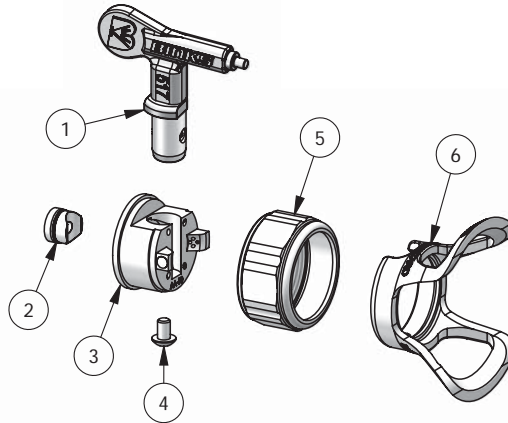

ITEM NO.	PART NO.	DESCRIPTION	HVLP	LVMP
			54-5924-K	54-5925-K
			AA10	9X-L
1	see pages 14-15	TWIST TIP	—	—
2	54-7539-K2	TWIST TIP BRACE	1	1
3		TWIST TIP AIR CAP COLOR	BLACK	SILVER
4	54-5930	RETAINING SCREW	1	1
5		TWIST TIP RETAINING RING	1	1
6		TWIST TIP GUARD	1	1

TEST AIR CAP KITS: 54-5932-K

MAINTENANCE AND CLEANING

Maintenance of air-assist airless spray guns includes three areas:

- fluid tip wear and replacement
- lubrication
- cleaning of the gun

FLUID TIPS

Operating an air-assist airless spray gun with a worn fluid tip will result in increased usage of spraying material and therefore, hazardous air pollutants. For example, an increase in the diameter of a tip from .4 to .5mm [0.015 to 0.021 in] due to wear can result in up to a 100 percent increase in material consumption and cost. To prevent waste in spraying material and non-value-added costs, a maintenance schedule that includes fluid tip inspection and replacement, should be established.

LUBRICATION

Proper lubrication is essential for optimum spray gun performance. Lubrication allows the equipment to operate easily and correctly. The spray gun should be lubricated after each cleaning. The points that need lubrication during the maintenance of air-assist airless spray guns include the fluid needle packing and trigger pivot point.

CAUTION

Never immerse the entire gun in solvent or thinners. Some gun parts will lose their lubricative film and wear more quickly. Additionally, solvents may carry impurities throughout the gun body and allow them to clog small air and fluid passages.

CLEANING

The following steps summarize the procedure for cleaning air- assist airless spray guns:

1. Turn off the air supply to the gun.
2. Turn off air supply to the pump and relieve fluid pressure. This may be accomplished by opening the bypass valve, if so equipped.
3. Place the material suction tube into a solvent container. If the pump is directly immersed in material, remove the pump and immerse it in a container containing solvent.

4. Engage the gun trigger safety switch into the locked position (move down).
5. Remove the fluid or twist tip and place it in a closed solvent container.

NOTE

Use only compatible solvents that are identified as approved for cleaning and wash-off use.

6. Adjust the pump air supply regulator to its lowest level (turning knob counter-clockwise).
7. Release the gun trigger safety switch into the unlocked position (move up).
8. Turn on the air supply to the pump and close the bypass valve, if so equipped.
9. Slowly adjust the pump air supply regulator until the pump begins to cycle (turning knob clockwise).

WARNING

Failure to reduce pump air supply pressure or to use a closed container can result in material "bounce-back". Material "bounce back" can cause injury and damage.

NOTE

During cleaning, the gun may only be sprayed into a closed earth-grounded container, never flush the gun into the air or spray booth.

10. Trigger the gun into a closed earth-grounded container until the fluid runs clear.
11. Using a rag dampened with solvent, wipe the exterior surface of the gun. Additionally, some solvents are prohibited from being used for cleaning. The operator must take care to use only approved cleaning solvents for equipment cleaning. These materials are clearly labeled as approved for cleaning and wash off operations. If the operator has any question on selecting appropriate cleaning solvents, the operator should consult a supervisor or plant environmental staff.

MAINTENANCE — DISASSEMBLY

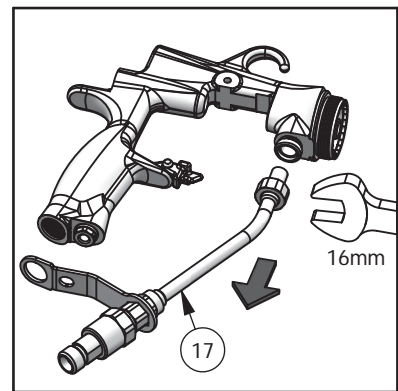
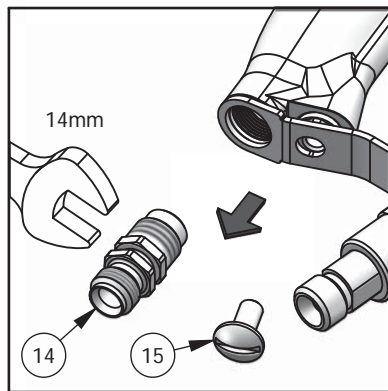
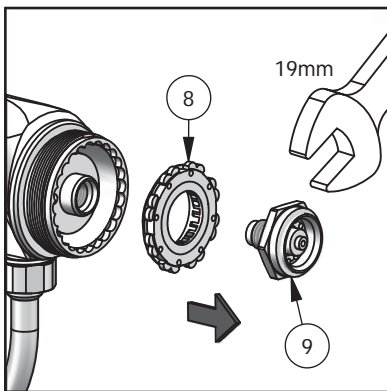
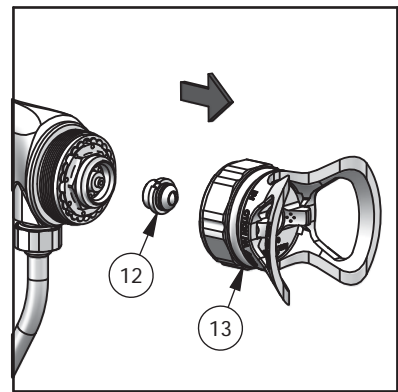
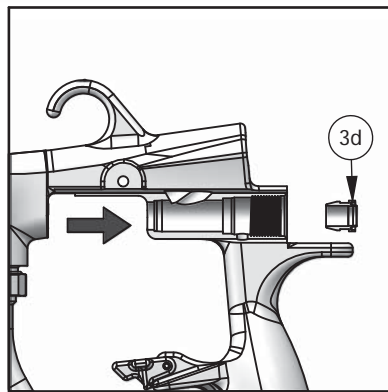
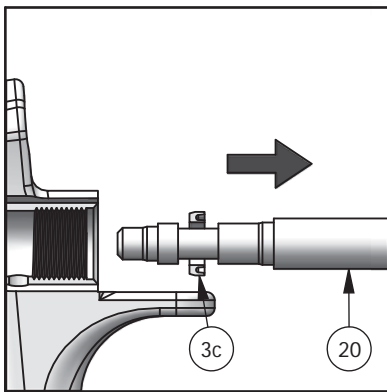
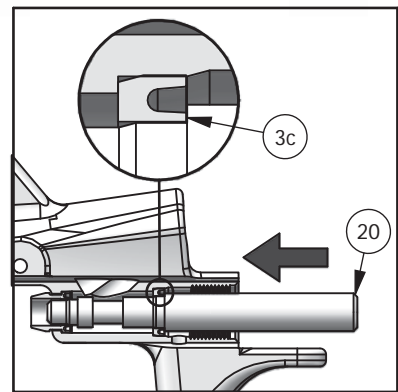
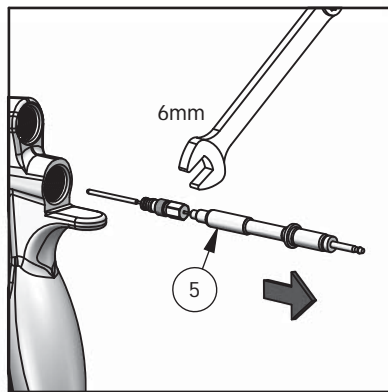
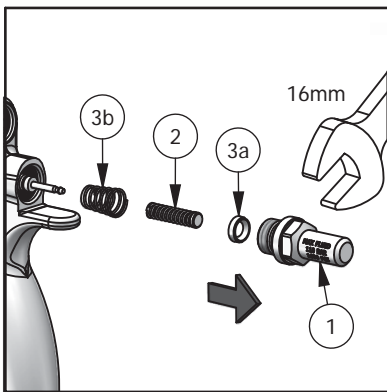
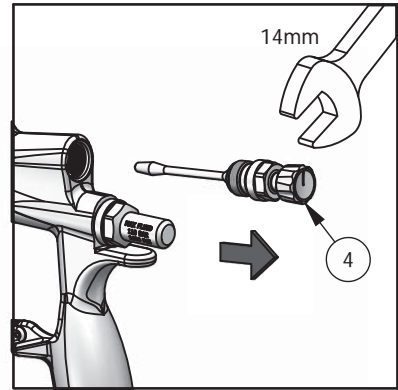
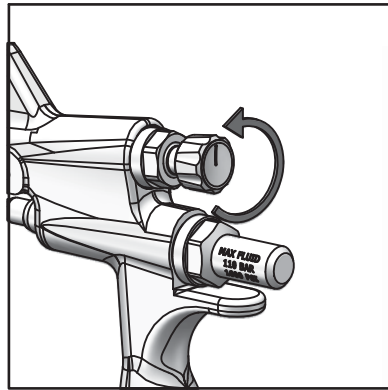
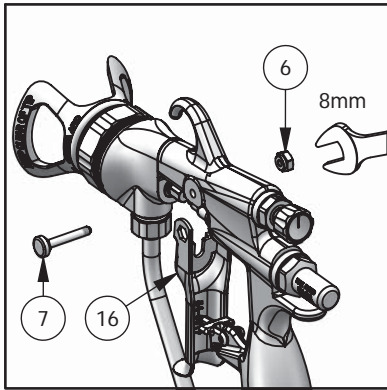

MAINTENANCE — ASSEMBLY

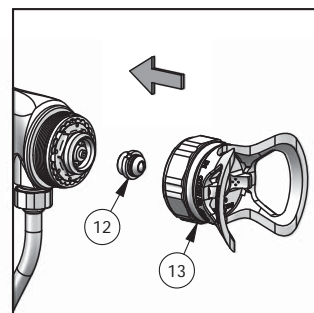
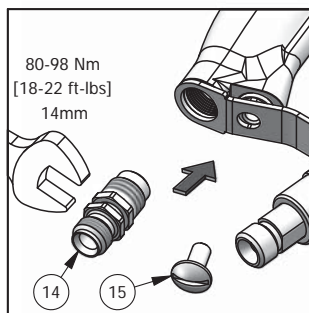
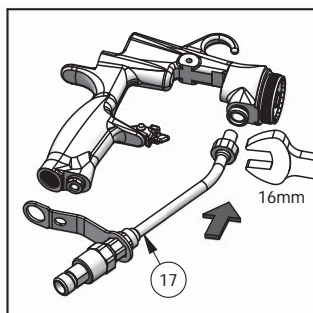
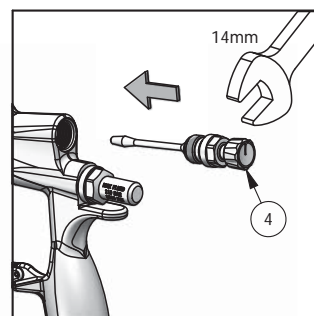
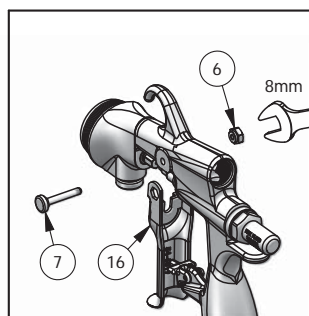
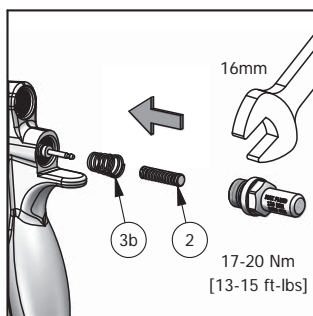
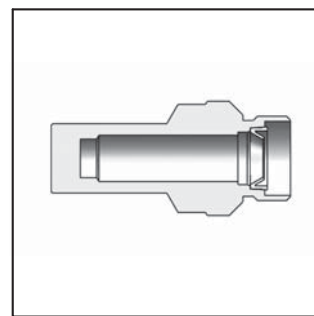
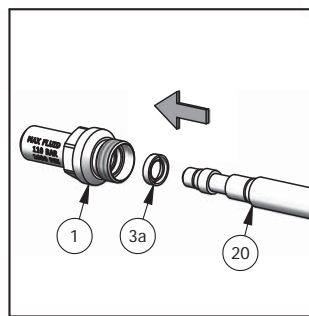
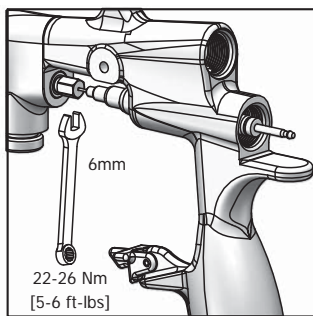
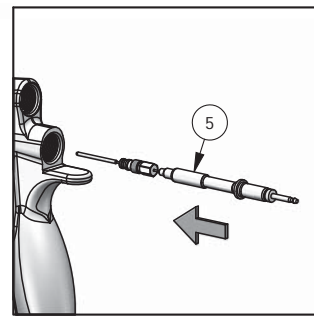
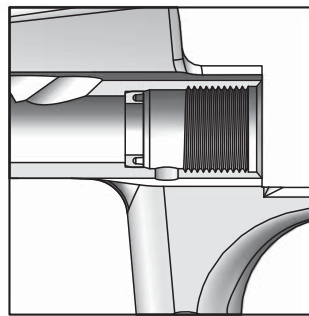
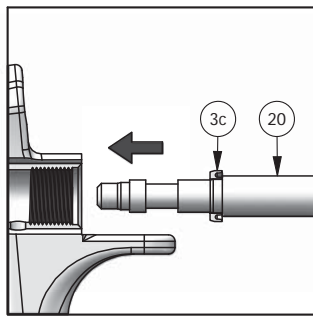
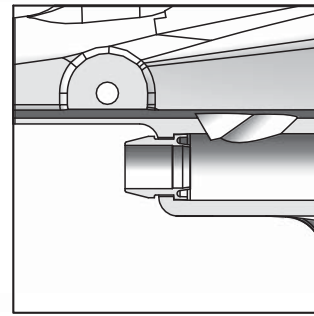
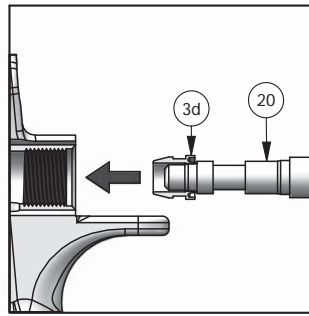
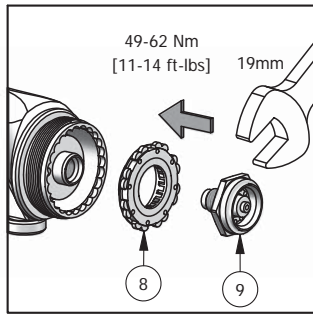

TROPHY AA TIP OFFERING

STANDARD TIP SIZES OFFERED

PART NUMBER	ORIFICE	FAN WIDTH *	CAPACITY **
RS-0702	.18mm [.007in]	50mm [2in]	106 CC [.028 GPM]
RS-0704		100mm [4in]	
RS-0706		150mm [6in]	
RS-0708		200mm [8in]	
RS-0902	.23mm [.009in]	50mm [2in]	148 CC [.039 GPM]
RS-0904		100mm [4in]	
RS-0906		150mm [6in]	
RS-0908		200mm [8in]	
RS-0910		250mm [10in]	
RS-0912	300mm [12in]		
RS-1104	.28mm [.011in]	100mm [4in]	227 CC [.060 GPM]
RS-1106		150mm [6in]	
RS-1108		200mm [8in]	
RS-1110		250mm [10in]	
RS-1112		300mm [12in]	
RS-1114		350mm [14in]	
RS-1304	.33mm [.013in]	100mm [4in]	341 CC [.090 GPM]
RS-1306		150mm [6in]	
RS-1308		200mm [8in]	
RS-1310		250mm [10in]	
RS-1312		300mm [12in]	
RS-1314		350mm [14in]	
RS-1316		400mm [16in]	
RS-1506	.38mm [.015in]	150mm [6in]	454 CC [.120 GPM]
RS-1508		200mm [8in]	
RS-1510		250mm [10in]	
RS-1512		300mm [12in]	
RS-1514		350mm [14in]	
RS-1516		400mm [16in]	
RS-1518		450mm [18in]	
RS-1706	.43mm [.017in]	150mm [6in]	606 CC [.160 GPM]
RS-1708		200mm [8in]	
RS-1710		250mm [10in]	
RS-1712		300mm [12in]	
RS-1714		350mm [14in]	
RS-1716		400mm [16in]	
RS-1718	450mm [18in]		
RS-1816	.46mm [.018in]	400mm [16in]	681 CC [.180 GPM]

STANDARD TIP SIZES OFFERED

PART NUMBER	ORIFICE	FAN WIDTH *	CAPACITY **
RS-1906	.48mm [.019in]	150mm [6in]	719 CC [.190 GPM]
RS-1908		200mm [8in]	
RS-1910		250mm [10in]	
RS-1912		300mm [12in]	
RS-1914		350mm [14in]	
RS-1916		400mm [16in]	
RS-1918		450mm [18in]	
RS-2110		.53mm [.021in]	
RS-2112	300mm [12in]		
RS-2114	350mm [14in]		
RS-2116	400mm [16in]		
RS-2118	450mm [18in]		
RS-2410	.61mm [.024in]	250mm [10in]	1173 CC [.310 GPM]
RS-2412		300mm [12in]	
RS-2414		350mm [14in]	
RS-2416		400mm [16in]	
RS-2418		450mm [18in]	
RS-2710	.69mm [.027in]	250mm [10in]	1457 CC [.385 GPM]
RS-2712		300mm [12in]	
RS-2714		350mm [14in]	
RS-2716		400mm [16in]	
RS-2718		450mm [18in]	

* Fan width based on 69 bar [1000 PSI] of water sprayed at 300mm [12in] from surface. Actual results may vary based on material sprayed.

** Capacity based on 34 bar [500 PSI] of fluid pressure using water pressure.

REPLACEMENT TIP SEALS FOR STANDARD STYLES:

RS-5000-K5 Multi-pack of 5 pieces

RS-5000-K10 Multi-pack of 10 pieces

TROPHY AA TIP OFFERING

FINE FINISH TIP SIZES OFFERED

PART NUMBER	ORIFICE	FAN WIDTH *	CAPACITY **	REPLACEABLE SEAL
RS-0909-F	.23mm [.009in]	250mm [10in]	148 CC [.039 GPM]	RS-5858-K5
RS-0911-F		300mm [12in]		
RS-1109-F	.28mm [.011in]	200mm [8in]	227 CC [.060 GPM]	RS-5859-K5
RS-1111-F		250mm [10in]		
RS-1113-F		300mm [12in]		
RS-1115-F		350mm [14in]		
RS-1309-F	.33mm [.013in]	250mm [10in]	341 CC [.090 GPM]	RS-5860-K5
RS-1311-F		300mm [12in]		
RS-1313-F		350mm [14in]		
RS-1315-F		400mm [16in]		
RS-1509-F	.38mm [.015in]	250mm [10in]	454 CC [.120 GPM]	RS-5861-K5
RS-1511-F		300mm [12in]		
RS-1513-F		350mm [14in]		
RS-1515-F		400mm [16in]		
RS-1517-F	.43mm [.017in]	450mm [18in]	606 CC [.160 GPM]	RS-5862-K5
RS-1709-F		250mm [10in]		
RS-1711-F		300mm [12in]		
RS-1713-F		350mm [14in]		
RS-1715-F		400mm [16in]		
RS-1717-F	450mm [18in]			

* Fan width based on 69 bar [1000 PSI] of water sprayed at 300mm [12in] from surface. Actual results may vary based on material sprayed.

** Capacity based on 34 bar [500 PSI] of fluid pressure using water pressure.

TWIST TIP SIZES OFFERED

PART NUMBER	ORIFICE	FAN WIDTH ***	CAPACITY ****
9-211-75	.28mm [.011in]	100mm [4in]	454 CC [.120 GPM]
9-213-75	.33mm [.013in]		681 CC [.180 GPM]
9-215-75	.38mm [.015in]		908 CC [.240 GPM]
9-217-75	.43mm [.017in]		1173 CC [.310 GPM]
9-307-75	.18mm [.007in]	150mm [6in]	189 CC [.050 GPM]
9-309-75	.23mm [.009in]		341 CC [.090 GPM]
9-311-75	.28mm [.011in]		454 CC [.120 GPM]
9-313-75	.33mm [.013in]		681 CC [.180 GPM]
9-315-75	.38mm [.015in]		908 CC [.240 GPM]
9-317-75	.43mm [.017in]		1173 CC [.310 GPM]
9-319-75	.48mm [.019in]		1457 CC [.385 GPM]
9-409-75	.23mm [.009in]		341 CC [.090 GPM]
9-411-75	.28mm [.011in]	200mm [8in]	454 CC [.120 GPM]
9-413-75	.33mm [.013in]		681 CC [.180 GPM]
9-415-75	.38mm [.015in]		908 CC [.240 GPM]
9-417-75	.43mm [.017in]		1173 CC [.310 GPM]
9-419-75	.48mm [.019in]		1457 CC [.385 GPM]
9-421-75	.53mm [.021in]		1779 CC [.470 GPM]
9-435-75	.89mm [.035in]		4959 CC [1.31 GPM]
9-509-75	.23mm [.009in]		341 CC [.090 GPM]
9-511-75	.28mm [.011in]		454 CC [.120 GPM]
9-513-75	.33mm [.013in]		681 CC [.180 GPM]
9-515-75	.38mm [.015in]		908 CC [.240 GPM]
9-517-75	.43mm [.017in]		1173 CC [.310 GPM]
9-519-75	.48mm [.019in]	1457 CC [.385 GPM]	
9-521-75	.53mm [.021in]	1779 CC [.470 GPM]	
9-523-75	.58mm [.023in]	2158 CC [.57 GPM]	
9-525-75	.64mm [.025in]	2536 CC [.670 GPM]	
9-611-75	.28mm [.011in]	300mm [12in]	454 CC [.120 GPM]
9-613-75	.33mm [.013in]		681 CC [.180 GPM]
9-615-75	.38mm [.015in]		908 CC [.240 GPM]
9-617-75	.43mm [.017in]		1173 CC [.310 GPM]
9-619-75	.48mm [.019in]		1457 CC [.385 GPM]
9-621-75	.53mm [.021in]		1779 CC [.470 GPM]
9-623-75	.58mm [.023in]		2158 CC [.57 GPM]
9-625-75	.64mm [.025in]		2536 CC [.670 GPM]
9-627-75	.69mm [.027in]		2801 CC [.740 GPM]
9-631-75	.79mm [.031in]		3899 CC [1.03 GPM]
9-635-75	.89mm [.035in]		4959 CC [1.31 GPM]
9-713-75	.33mm [.013in]		350mm [14in]
9-715-75	.38mm [.015in]	908 CC [.240 GPM]	
9-717-75	.43mm [.017in]	1173 CC [.310 GPM]	

*** Fan width based on 152 bar [2200 PSI] of latex sprayed at 300mm [12in] from surface. Actual results may vary based on material sprayed.

**** Capacity based on 152 bar [2200 PSI] of fluid pressure using latex.

WARRANTY POLICY

This product is covered by Carlisle Fluid Technologies' materials and workmanship limited warranty. The use of any parts or accessories, from a source other than Carlisle Fluid Technologies, will void all warranties. Failure to reasonably follow any maintenance guidance provided may invalidate any warranty.

For specific warranty information please contact Carlisle Fluid Technologies.

Carlisle Fluid Technologies is a global leader in innovative finishing technologies. Carlisle Fluid Technologies reserves the right to modify equipment specifications without prior notice.

DeVilbiss®, Ransburg®, ms®, BGK®, and Binks®
are registered trademarks of Carlisle Fluid Technologies, Inc.

©2018 Carlisle Fluid Technologies, Inc.
All rights reserved.

For technical assistance or to locate an authorized distributor,
contact one of our international sales and customer support locations.

Region	Industrial/Automotive	Automotive Refinishing
Americas	Tel: 1-800-992-4657 Fax: 1-888-246-5732	Tel: 1-800-445-3988 Fax: 1-800-445-6643
Europe, Africa, Middle East, India	Tel: +44 (0)1202 571 111 Fax: +44 (0)1202 573 488	
China	Tel: +8621-3373 0108 Fax: +8621-3373 0308	
Japan	Tel: +81 45 785 6421 Fax: +81 45 785 6517	
Australia	Tel: +61 (0) 2 8525 7555 Fax: +61 (0) 2 8525 7575	

For the latest information about our products, visit www.carlisleleft.com